

VELVET 1540B

Refrigerated pastry display

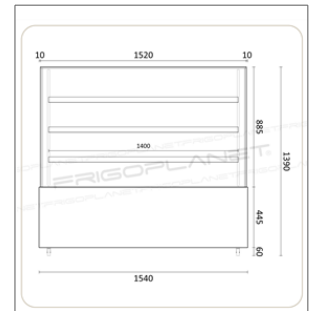

- Steel, glass and plastic external and internal structure
- Base in black painted steel
- Ventilated refrigeration
- Incorporated refrigeration unit
- Digital control unit
- Automatic condensation evaporation
- Double glazed on each side
- Anti-fog ventilation ducts for side and front external glasses
- Removable sliding doors
- Height-adjustable shelves
- Internal LED lighting on each shelf
- Swivel casters (2 with brake)
- Equipped with 1 1400x310 mm removable glass shelf and 2 1400x370 mm removable glass shelves
- 1450x370 mm bottom chamber removable glass

TECHNICAL FEATURES

MODEL	VELVET 1540B
ENERGY CLASS	B (2019/2018/UE)
POWER WATT	530
POWER SUPPLY	230/1N/50
TEMPERATURE °C	+2 ÷ +8
REFRIGERANT	R290
MAX. TEMP. / HUMIDITY	+30 °C / 55% HR
DIMENSIONS MM	1540x688x1390h
SHELVES NO. AND TYPE	1 x 1400x310 mm 2 x 1400x370 mm Bottom 1450x370 mm
CAPACITY L	670
NET WEIGHT KG	229
GROSS WEIGHT KG	252
PACKING DIMENSIONS CM	161x76x153h