

VELVET 1840B

Refrigerated pastry display

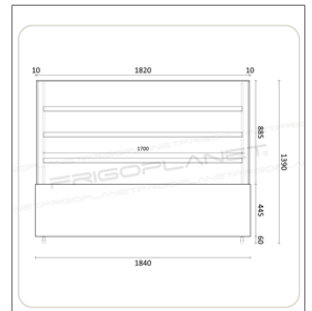

- Steel, glass and plastic external and internal structure
- Base in black painted steel
- Ventilated refrigeration
- Incorporated refrigeration unit
- Digital control unit
- Automatic defrost
- Automatic condensation evaporation
- Double glazed on each side
- Anti-fog ventilation ducts for side and front external glasses
- Removable sliding doors
- Height-adjustable shelves
- Internal LED lighting on each shelf
- Swivel casters (2 with brake)
- Equipped with 1 1700x310 mm removable glass shelf and 2 1700x370 mm removable glass shelves
- 1750x370 mm bottom chamber removable glass

TECHNICAL FEATURES

| | |
|------------------------------|--|
| MODEL | VELVET 1840B |
| ENERGY CLASS | B (2019/2018/UE) |
| POWER WATT | 530 |
| POWER SUPPLY | 230/1N/50 |
| TEMPERATURE °C | +2 ÷ +8 |
| REFRIGERANT | R290 |
| MAX. TEMP. / HUMIDITY | +30 °C / 55% HR |
| DIMENSIONS MM | 1840x688x1390h |
| SHELVES NO. AND TYPE | 1 x 1700x310 mm 2 x 1700x370 mm Bottom 1750x370 mm |
| CAPACITY L | 810 |
| NET WEIGHT KG | 245 |
| GROSS WEIGHT KG | 290 |
| PACKING DIMENSIONS CM | 191x76x153h |