

## BOUNTY 650

### Refrigerated pastry display

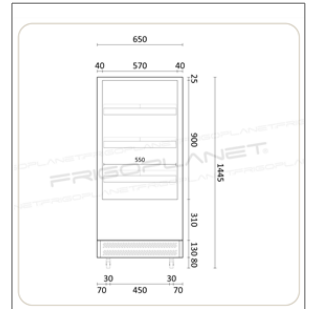

- Stainless steel, glass and plastic external and internal structure
- Ventilated refrigeration
- Incorporated refrigeration unit
- Digital control unit
- Automatic defrost
- Automatic condensation evaporation
- Double glazed on each side
- Hinged door
- Height-adjustable shelves
- Internal LED lighting on each shelf
- Swivel casters (2 with brake)
- Equipped with 2 550x390 mm removable glass shelves and 1 550x450 mm removable glass shelf
- 610x470 mm bottom chamber removable glass

## TECHNICAL FEATURES

<b>MODEL</b>	BOUNTY 650
<b>ENERGY CLASS</b>	C (2019/2018/UE)
<b>POWER WATT</b>	480
<b>POWER SUPPLY</b>	230/1N/50
<b>TEMPERATURE °C</b>	+2 ÷ +8
<b>REFRIGERANT</b>	R290
<b>MAX. TEMP. / HUMIDITY</b>	+30 °C / 55% HR
<b>DIMENSIONS MM</b>	650x805x1445h
<b>SHELVES NO. AND TYPE</b>	2 x 550x390 mm 1 x 550x450 mm Bottom 610x470 mm
<b>CAPACITY L</b>	350
<b>NET WEIGHT KG</b>	135
<b>GROSS WEIGHT KG</b>	158
<b>PACKING DIMENSIONS CM</b>	75x90x166h